

HTC SERIES

HTC- 4DE

2 HEAT/3 COOL CONTROLLER with MODULATING ECONOMY CYCLE COMPARITOR

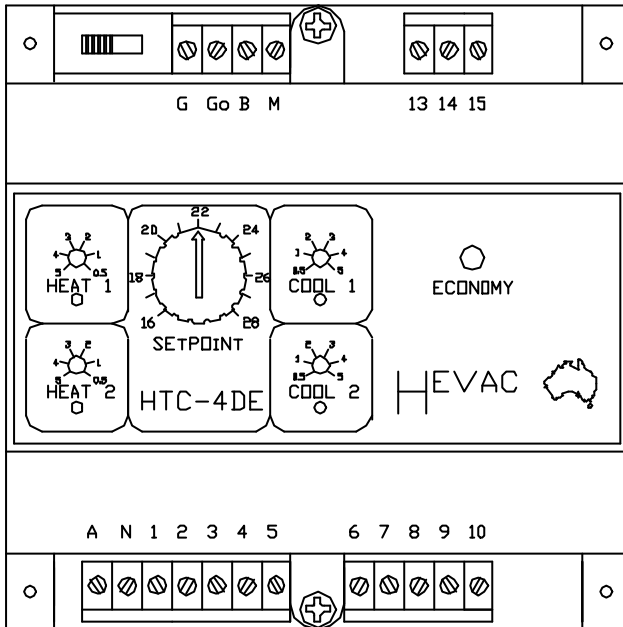

*The **HTC-4DE** temperature controller is primarily designed for the control of 2 Heat and 2 Cool air-conditioning units, and also incorporates a Modulating Economy Cycle Output with a Comparitor Override.*

This output is produced by comparing the outside air temperature to either the return air or room temperatures.

*If the **HTC-4DE** is in the cooling mode and the outside air is lower than the room/return air temperature the Economy output will start modulating.*

Features

- Australian made and designed.
- Dual supply voltage 24v or 240v A.C (User Selectable)
- 10 AMP (resistive) Potential free relay contacts.
- L.E.D Indication of all outputs.
- Various remote sensor options available.
- Comparitor Override via room or return air sensor.
- Modulating 0-10VDC Economy Cycle Output.

HEAD OFFICE:

54 Howleys Road,
Notting Hill, Vic. 3168
Phone: (03) 9562 7888
Fax: (03) 9562 7835

VISIT OUR WEB SITE AT

www.hevac.com.au
EMAIL
SALES: sales@hevac.com.au
TECHNICAL: technical@hevac.com.au

HTC-4DE Technical Specifications

Power supply (User Selectable)	24VAC or 240VAC
Power consumption 240 volts	7 VA
Power consumption 24 volts	1 VA
Heating and Cooling relay outputs	240VAC 10 amp resistive, 3 amp inductive
Temperature range	16 to 28 Degrees Centigrade
Switching differential for STAGE 1	0.3 Degrees Centigrade
Switching differential for STAGE 2	0.7 Degrees Centigrade
STAGE 1 & 2 start point adjustment range	0.5 to 5.0 Degrees Centigrade
Economy cycle output	0-10VDC
Economy Cycle Output Proportional Band	1.0 Degrees Centigrade
Output indication	Green LED for Cooling Red LED for Heating
(Located on the right hand side of control fascia)	Yellow LED for Economy Cycle Output
Mounting method	35mm DIN rail (Not supplied)

Dimensions

ALL DIMENSIONS IN MILLIMETRES

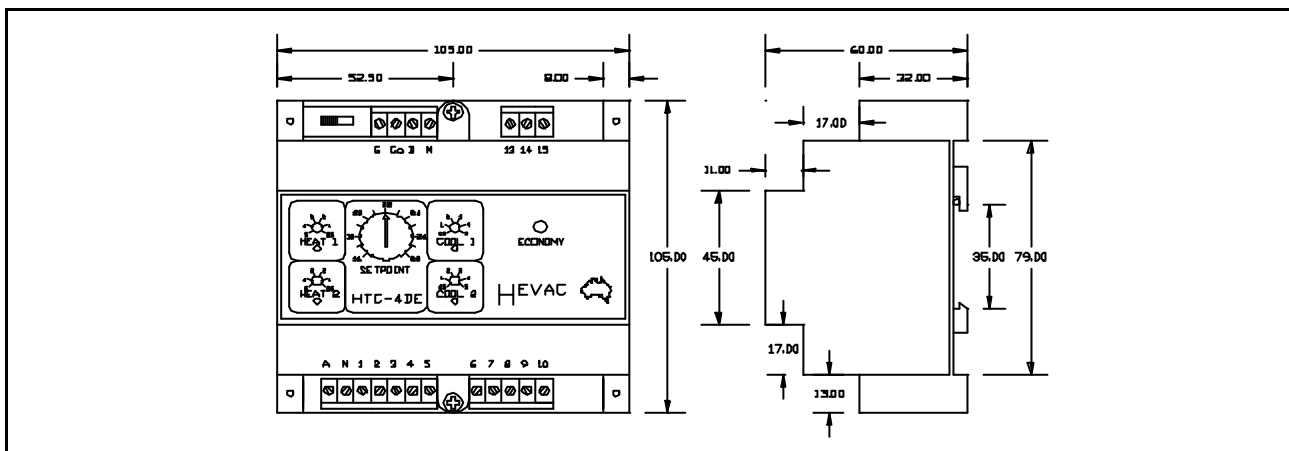

Terminal Designations

G	24 VOLT AC SUPPLY ACTIVE	2	HEATING STAGE 2 OUTPUT
Go	24 VOLT AC SUPPLY GROUND REFERENCE	3	HEATING STAGE 1 OUTPUT
B	ROOM SENSOR INPUT	4	(HEATING STAGE 1 & R/V FOR COOL) COMMON
M	COMMON FOR ALL SENSOR INPUTS	5	REVERSING VALVE FOR COOLING OUTPUT
13	0-10VDC ECONOMY CYCLE OUTPUT	6	COOLING STAGE 1 OUTPUT
14	RETURN AIR SENSOR INPUT (SEE NOTE BELOW)	7	(COOLING STAGE 1 & R/V FOR HEAT) COMMON
15	OUTDOOR SENSOR INPUT	8	REVERSING VALVE FOR HEATING OUTPUT
A & N	240 VOLT AC SUPPLY	9	COOLING STAGE 2 COMMON
1	HEAT STAGE 2 COMMON	10	COOLING STAGE 2 OUTPUT