

# HRC SERIES

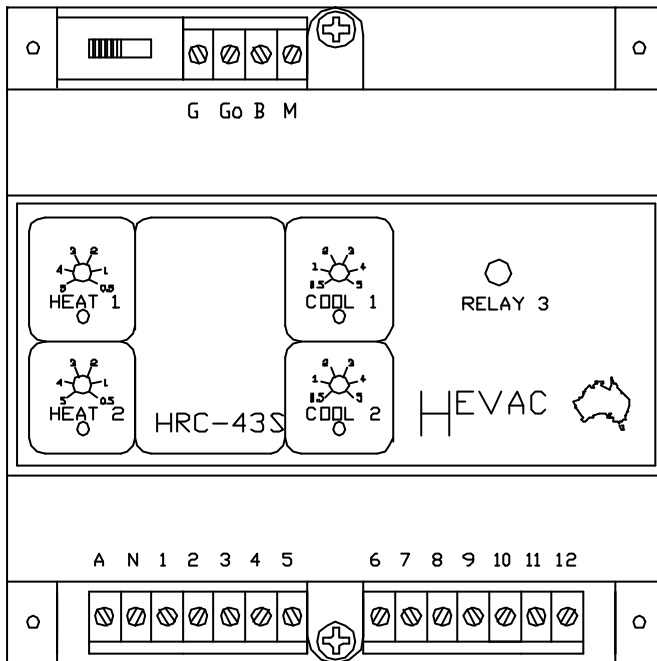

## HRC-43S

### 3 HEAT/3 COOL STAGING RELAY

The **HRC-43S** staging relay is intended for use with the slave output on the HTC analogue range of controllers.

This module allows for three extra heating and cooling stages designed for the control of triple compressor HEAT PUMP units.

The third relay stage is set to energise 3 oC above setpoint and 3 oC below setpoint.

The **HRC-43S** controller is ideally suited for DIN rail mounting in a switchboard, or directly inside the A/C unit if required.

### Features

- Australian made and designed.
- Dual supply voltage 24v or 240v A.C (User Selectable)
- 10 AMP (resistive) Potential free relay contacts.
- L.E.D Indication of all outputs.
- Compatible with all the HEVAC HTC analogue range.
- Mounts in most M.C.B enclosures.
- Third relay stage for Triple Compressor HEAT PUMPS.

## HRC-43S Technical Specifications

Power supply (User Selectable)	24VAC or 240VAC
Power consumption 240 volts	7 VA
Power consumption 24 volts	1 VA
Heating and Cooling relay outputs	240VAC 10 amp resistive, 3 amp inductive
Input terminal voltage range	0-10VDC
Switching differential for STAGE 1	0.3 Degrees Centigrade
Switching differential for STAGE 2	0.7 Degrees Centigrade
Switching differential for STAGE 3	1.0 Degrees Centigrade
STAGE 1 & 2 start point adjustment range	0.5 to 5.0 Degrees Centigrade
Third Compressor Stage start point	3.0 Degrees above and below setpoint
Output indication	Green LED for Cooling Red LED for Heating Yellow LED for Third Compressor Stage
(Located on the right hand side of control fascia)	
Mounting method	35mm DIN rail (Not supplied)

## Dimensions

ALL DIMENSIONS IN MILLIMETRES

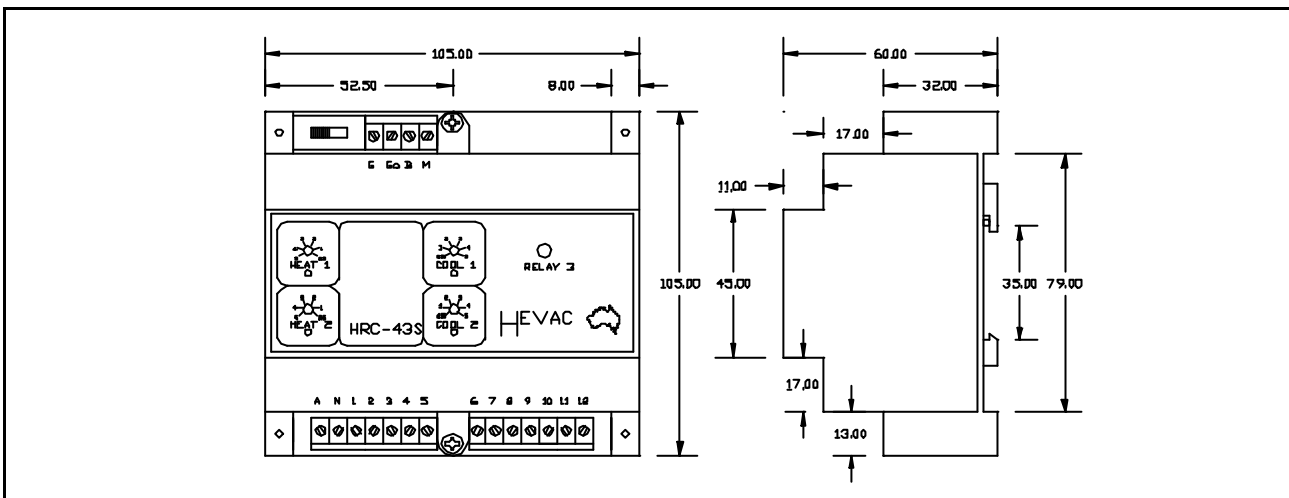

## Terminal Designations

<b>G</b>	24 VOLT AC SUPPLY ACTIVE	<b>4</b>	(HEATING STAGE 1 & R/V FOR COOL) COMMON
<b>Go</b>	24 VOLT AC SUPPLY GROUND REFERENCE	<b>5</b>	REVERSING VALVE FOR COOLING OUTPUT
<b>B</b>	0-10VDC INPUT	<b>6</b>	COOLING STAGE 1 OUTPUT
<b>M</b>	SIGNAL GROUND	<b>7</b>	(COOLING STAGE 1 & R/V FOR HEAT) COMMON
<b>A &amp; N</b>	240 VOLT AC SUPPLY	<b>8</b>	REVERSING VALVE FOR HEATING OUTPUT
<b>1</b>	HEAT STAGE 2 COMMON	<b>9</b>	COOLING STAGE 2 COMMON
<b>2</b>	HEATING STAGE 2 OUTPUT	<b>10</b>	COOLING STAGE 2 OUTPUT
<b>3</b>	HEATING STAGE 1 OUTPUT	<b>11</b>	COMPRESSOR STAGE 3 COMMON
		<b>12</b>	COMPRESSOR STAGE 3 OUTPUT